

Data sheet WM18700B-340

18700 lpd (4940 gpd)

Without energy recovery system



AUTOMATED FEATURES:

- User friendly interface with single button operation
- Output for start/stop of feed pump
- Input for start/stop on tank level switch
- Automatic fresh water flush system (start/stop, 4 hours/24 hours)
- Shut down at high/low membrane pressure, low/high feed water pressure, high product water flow, high salinity product water
- Integrated timer for setting quiet intervals

METERS/MONITORS:

- Custom made controller enables close monitoring
- Coloured icons giving continuous overview
- Single button gives access to lot of data:
 - Product water TDS
 - Product water flow
 - Hour counter
 - Approx. cumulative production
 - Feed/flush water pressure
 - Membrane pressure

PARTS AND MATERIALS:

- Danfoss APP in duplex and super duplex steel
- Major saltwater wetted steel parts in duplex or super duplex steel
- Frame in high quality PEHD polymer
- Overvoltage protection

OPTIONS:

- GSM based monitoring, control and alarm messaging
- Motor soft starter

Data sheet WM18700B-340

Hydraulic Data	50 Hz / 60 Hz
Nominal water production l/day (gallon/day)	18700 (4940)
Nominal membrane pressure bar (psi)	56.0 (812) / 56.6 (821)
Total dissolved solids, fresh water (TDS) mg/l	<550
Stabilized salt rejection %	99.4
Membrane pressure range bar (psi)	20-69 (290-1001)
Membrane pressure control	Manual
Total dissolved solids range, feed water (TDS) ² mg/l	1500 – 45000
Minimum inlet flow (feed & flush) m ³ /h (gallon/h)	2.66 (703) / 2.60 (687)
Minimum flush water volume (3 x flush) l (gallon)	70 (18.5)
Minimum inlet pressure (feed & flush) bar (psi)	0.5 (7.3)
Maximum inlet pressure (feed & flush) bar (psi)	5 (73)
Maximum back pressure on fresh water bar (psi)	1.0 (14.5)
Nominal pump input power ¹ kW	4.9
Specific pump energy ¹ kWh/m ³ (kWh/1000 gallon)	6.3 (24)

Electrical Data	50 Hz/60 Hz
Motor size kW (hp)	7.5 (10.1) / 9 (12.1)
Maximum consumed power kW	6.9 / 6.8
Motor voltage V	3 ph: 400/480-Δ or 690/830-Y
Motor speed (50/60 Hz grid) rpm	2900 / 3480
Feed pump control	Relay output
Water level signal	Relay input
Electrical ingress protection	IP 54

Dimensions	
Watermaker (LxWxH) mm (inch)	1192x462x750 (47x18x30)
Control box (LxWxH) mm (inch)	392x200x155 (12x8x6)
Water inlet/outlet (OD) mm (inch)	22 (0.9)
Weight kg (lb)	130 (287)

Operating limits	
Feed water temperature ² °C (°F)	0.5 – 45 (32.9 – 113)
Ambient temperature °C (°F)	0.5 – 50 (32.9 – 122)

Components	
Membrane type	DOW/AqSep seawater
Membrane quantity	6
Membrane size Inches	3x40
High pressure pump	APP 2.5 / 2.2 - Duplex steel
Lubrication, coolants etc.	Not required
Frame	Plastic
Saltwater exposed parts	Duplex/316 steel, plastic
Fresh water parts	316 steel, brass, plastic
Controller	Custom made with display (GSM interface as option) (Motor soft starter as option)

Part Number ³	
WM18700B-340 3x480 V, 60 Hz, 3480 rpm	182B0043
WM18700B-340 3x400 V, 50 Hz, 2900 rpm	182B0045

Rated performance may vary ±15%, Nominal conditions: 25 °C seawater at 32.000 mg/l TDS

¹ Based on simulation in ROSA design software from Dow Water & Process Solutions

² Water production may need to be adjusted to match the specific combination of temperature and total dissolved solids in the feed water (TDS)

³ Contact AqSep for alternative motor voltages/frequencies

Data sheet WM18700B-340

mm (inch)

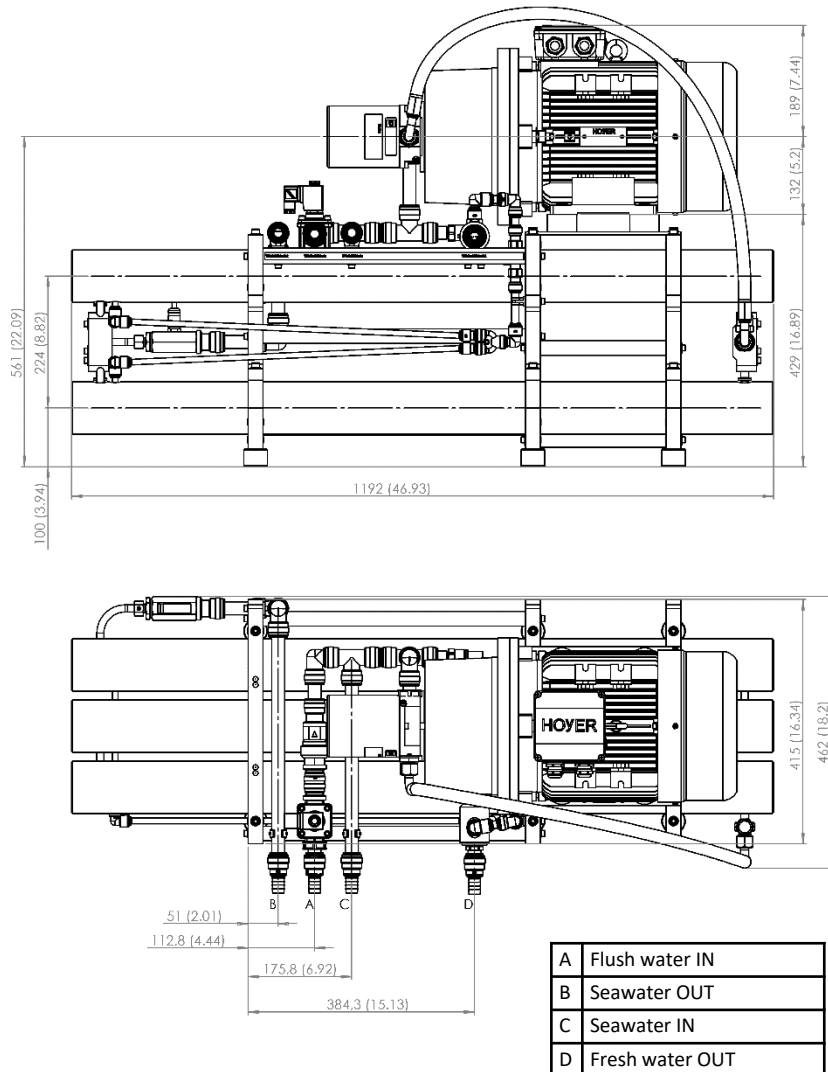

Control Box

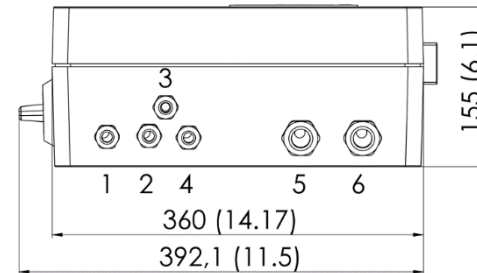

1	Power Connection
2	Electrical motor
3	Solenoid valve
4	Cable tree – sensors
5	Feed pump signal – XS1
6	Level switch signal – XS2

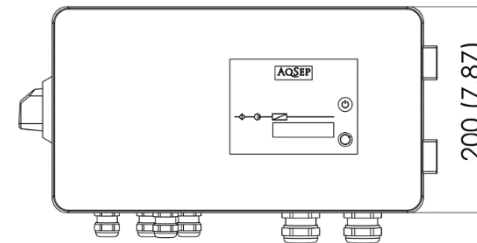

The integrated control box is connected to the sensors via a cable tree. Separate cables connect the electrical motor and valve.

Mating electrical connectors for start & stop of well pump/isolating valve as well as level switch signal are located inside the control box.

The optional GSM modem is also fitted to the control box.