



SCROLLWORK

Cabled Hat & Cowl Set

by Irina Dmitrieva



SCROLLWORK COMPONENTS

Materials

150 yards (hat) or 260 yards (cowl) of worsted weight wool yarn

Each project requires 2 skeins of Brooklyn Tweed *Shelter* (100% American Targhee-Columbia Wool; 140 yards/50g); both hat and cowl can be made with 3 skeins of yarn

Hat photographed in color *Wool Socks*

Cowl photographed in color *Soot*

Gauge

Working Gauge

19 stitches and 28 rounds = 4" in stockinette stitch with Needle A, before blocking

Finished Gauge

22 stitches and 26 rounds = 4" over cabled Pattern with Needle A, relaxed after wet-blocking

Additional Tools

Stitch marker, cable needle ("CN"), blunt tapestry needle

Needles

Size A

One 16" circular and one set of DPNs (hat only) in size needed to obtain gauge listed; suggested size: 4½ mm (US 7)

Size B

One 16" circular three sizes smaller than Gauge Needle; suggested size: 3½ mm (US 4)

Finished Dimensions

Cowl

31" circumference at base, 24" circumference at top, 9½" height
Measurements taken from relaxed fabric after blocking

Hat

18" brim circumference, 22" circumference at widest point, 9" height from base of ribbing to top-center of crown
Measurements taken from relaxed fabric after blocking
To fit average adult head sizes 21-24"

Skill Level



SCROLLWORK SCHEMATICS

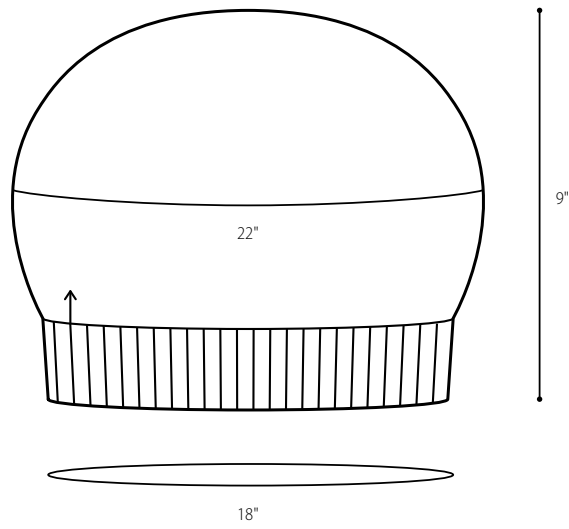
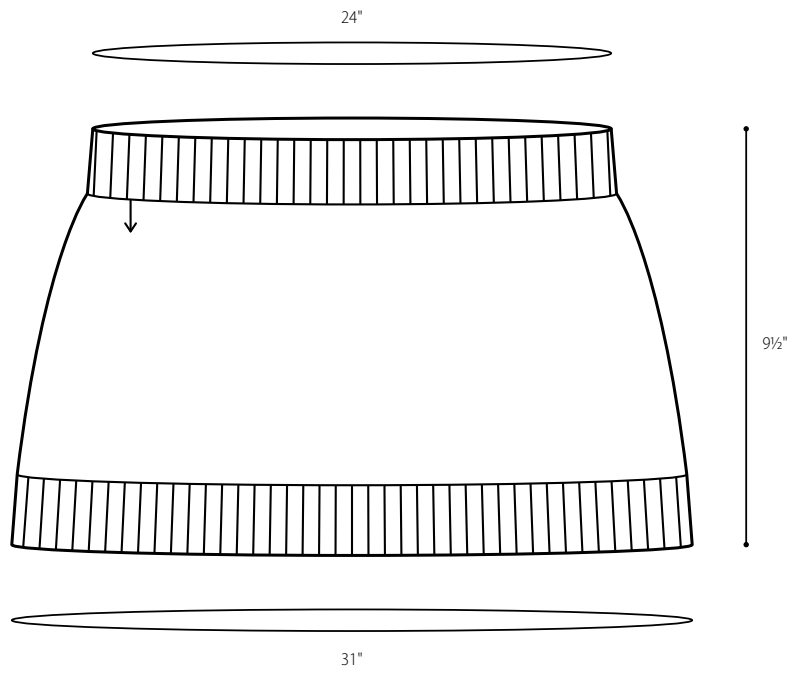

ABOUT THIS DESIGN

The *Scrollwork* hat and cowl set feature Irina Dmitrieva's signature interlocking aran stitches. Dmitrieva has a knack for weaving with cables – evidenced here by the elegant integration of ribbed trims and crown shaping to create a seamless network of root-like motifs. Each accessory is a joy to knit and a great addition to any knitter's wardrobe. Each project requires 2 skeins of *Shelter*, though both can be made with 3 skeins.

CONSTRUCTION NOTES

- Hat is worked circularly from the bottom up.
- Cowl is worked circularly from the top down.
- Cable motif and crown shaping (hat only) are provided in both written and charted form.

STITCH PATTERNS

Scrollwork Cable – Written Instructions

Scrollwork cable is a 16-stitch repeat and is worked 11 times per round for the cowl and 8 times per round for the hat. A chart for the cable is provided on page 8.

Round 1 (Setup): *Purl 1, knit 2, 2/2 RC (see *Legend* on page 7 for all cable abbreviations), purl 2, 2/2 LC, knit 2, purl 1; repeat from * to the end of round.

Round 2 (Setup): Work the stitches as they present themselves – knitting the knits and purling the purls.

Round 3: *Purl 1, 2/2 RC, knit 2, purl 2, knit 2, 2/2 LC, purl 1; repeat from * to the end of round.

Round 4 (and all subsequent even rounds): Work the stitches as they present themselves – knitting the knits and purling the purls. (See special instructions below for Round 8)

Round 5: *Purl 1, knit 2, 2/2 RT, purl 2, 2/2 LT, knit 2, purl 1; repeat from * to the end of round.

Round 7: *2/3 RT, purl 6, 2/3 LT; repeat from * to the end of round.

Round 8 (Shift Marker): Work as for all other even-numbered rounds until 2 stitches remain in round, slip 2 from L to R needle, remove marker, replace 2 slipped stitches on L needle, replace marker. This indicates the new beginning-of-round.

Round 9 (Shift Marker): *2/2 LC, purl 12; repeat from * to the end of round, remove marker, knit 2, replace marker. This indicates the new beginning-of-round.

Round 11: *Scroll Left (see *Legend*), purl 6, Scroll Right; repeat from * to the end of round.

Round 13: *Purl 1, knit 2, 2/2 LC, purl 2, 2/2 RC, knit 2, purl 1; repeat from * to the end of round.

Round 15: *Purl 1, 2/2 LT, knit 2, purl 2, knit 2, 2/2 RT, purl 1; repeat from * to the end of round.

Round 17: *Purl 3, 2/3 LT, 2/3 RT, purl 3; repeat from * to the end of round.

Round 19: *Purl 6, 2/2 LC, purl 6; repeat from * to the end of round.

Round 21: *Purl 3, Scroll Right, Scroll Left, purl 3; repeat from * to the end of round.

COWL

Upper Ribbing

With Needle B (sugg. 3½ mm/US 4), cast on 154 stitches using the Long-Tail Method. Place a marker and join work into the round, being careful not to twist your ring of stitches.

Ribbing Round: *[Purl 1, knit 2] twice, purl 1; repeat from * to the end of round.

Repeat the Ribbing Round 11 more times. (12 times total)

Increase Round: *Purl 1, knit 2, knit into the front and back of the next stitch (increasing one), knit 2, purl 1; repeat from * to the end of round. (22 stitches increased; 176 stitches now on needle)

Cabled Fabric

Switch to circular Needle A as you work the next round. You will work the remainder of cowl on this needle.

Work Rounds 1-22 of Scrollwork Cable, using either charted or written instructions.

Chart Notes:

- Scrollwork Cable is a 16-stitch repeat that is worked 11 times per round.
- All rounds are read from right to left.
- Beginning-of-Round marker placement will change on Rows 8 & 9, as noted by the asterisks (*). Refer to written instructions on these rounds for instructions on moving marker.

Repeat Rounds 3-22 of Scrollwork Cable again.

Repeat Rounds 3-4 of Scrollwork Cable once more.

Next Round: *Purl 1, knit 2, 2/2 RC, purl 2, 2/2 LC, knit 2, purl 1; repeat from * to the end of round.

Next Round: Work all stitches as they present themselves (knitting the knits and purling the purls).

Next Round: *Purl 1, 2/2 RT, knit 2, purl 2, knit 2, 2/2 LT, purl 1; repeat from * to the end of round.

Lower Ribbing

Ribbing Round: *Purl 1, knit 2, purl 1; repeat from * to the end of round.

Repeat the Ribbing Round 9 more times. (10 times total)

Neatly bind off in pattern with a relaxed tension.

Wet-block cowl following the instructions under *Finishing* (page 7).



HAT

Brim

With Needle B (sugg. 3½ mm/US 4), cast on 112 stitches using the Long-Tail Method. Place a marker and join work into the round, being careful not to twist your ring of stitches.

Ribbing Round: * [Purl 1, knit 2] twice, purl 1; repeat from * to the end of round.

Repeat the Ribbing Round 11 more times. (12 times total)

Increase Round: *Purl 1, knit 2, knit into the front and back of the next stitch (increasing one), knit 2, purl 1; repeat from * to the end of round. (16 stitches increased; 128 stitches now on needle)

Cabled Body

Switch to circular Needle A as you work the next round. You will work the remainder of hat with this needle size.

Work Rounds 1-22 of Scrollwork Cable, using either charted or written instructions.

Chart Notes:

- Scrollwork Cable is a 16-stitch repeat that is worked 8 times per round.
- All rounds are read from right to left.
- Beginning-of-Round marker placement will change on Rows 8 & 9, as noted by the asterisks (*). Refer to written instructions (page 4) on these rounds for instructions on moving marker.

Work Rounds 3-15 of Scrollwork Cable again.

Next Round (Shift Marker): Work all stitches as they present themselves (knitting the knits and purling the purls) until you reach the end-of-round, remove marker, purl 1, replace marker. This indicates the new beginning-of-round.



Shape Crown

Work Rounds 1-13 of Crown Chart (or, work these rounds from the written instructions provided below) switching to DPNs when necessary.

Chart Notes:

- Crown Chart begins as a 16-stitch repeat (*before* working Round 1) and ends as a 2-stitch repeat (*after* working Round 13); the chart is worked 8 times per round.
- All rounds are read from right to left.

Crown Chart - Written Instructions

Round 1: *P2tog, 2/3 LT, 2/3 RT, p2tog, purl 2; repeat from * to the end of round. (16 stitches decreased; 112 stitches remain)

Round 2 (and all subsequent even rounds): Work the stitches as they present themselves – knitting the knits and purling the purls.

Round 3: *Purl 2, p2tog, 2/2 LC, p2tog, purl 4; repeat from * to the end of round. (16 stitches decreased; 96 stitches remain)

Round 5: *P2tog, 2/1 RT, 2/1 LT, p2tog, purl 2; repeat from * to the end of round. (16 stitches decreased; 80 stitches remain)

Round 7: *K2tog, knit 1, purl 2, knit 1, SSK, purl 2; repeat from * to the end of round. (16 stitches decreased; 64 stitches remain)

Round 9: *Knit1, SSK, k2tog, knit1, purl 2; repeat from * to the end of round. (16 stitches decreased; 48 stitches remain)

Round 11: *SSK, k2tog, purl 2; repeat from * to the end of round. (16 stitches decreased; 32 stitches remain)

Round 13: *SSK, P2tog; repeat from * to the end of round. (16 stitches decreased; 16 stitches remain)

Break yarn, leaving an 8" tail. Using tapestry needle, thread yarn tail through remaining stitches two times, then pull snugly to close top of crown. Weave in all remaining ends invisibly on the WS of fabric.

Wet-block hat following the instructions under *Finishing* (page 7).

FINISHING

Wet-Blocking

Fill a sink or basin with warm water and a small amount of delicate dish soap or rinseless wool wash. Submerge fabric in water, gently squeezing out any air bubbles so that the piece can remain under water without being held there. Soak work for 30 minutes, allowing fabric to become completely saturated.











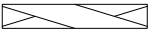

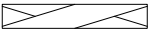
Drain the sink and remove work. If you have used dish soap (rather than rinseless wool wash), fill the sink again once or twice to rinse the soap from your fabric. Never place knitting directly under running water.

Squeeze out excess water from your work, taking care not to twist or wring fabric. Roll your fabric between two clean bath towels “burrito” style and firmly press towel roll. This will aid in removing moisture from the knitted piece. Remove piece from towels – your fabric should now feel damp but not saturated.

Lay finished project flat on an appropriate blocking surface, smoothing fabric flat with your hands. If blocking the hat, allow the crown to curve upward when work is laid flat.

For circular knitting projects, fabric will dry with creases at the sides if it is not repositioned during drying. For best results, rotate your work every 1-2 hours as it dries, changing the location of the side creases. If your work does dry with creases, you can easily steam them out afterwards using a steam iron or garment steamer.

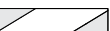
LEGEND

	Knit: Knit stitch		2/2 LC: Slip 2 stitches to CN and <i>hold in front</i> . Knit 2 stitches from L needle. Knit 2 stitches from CN
	Purl: Purl stitch		2/2 RC: Slip 2 stitches to CN and <i>hold in back</i> . Knit 2 stitches from L needle. Knit 2 stitches from CN
	K2tog: Knit two stitches together (<i>1 stitch decreased; leans right</i>)		2/2 LT: Slip 2 stitches to CN and <i>hold in front</i> . Purl 2 stitches from L needle. Knit 2 stitches from CN
	SSK: Slip 1 stitch from L to R needle knitwise, return stitch to L needle in its new orientation and knit two together through the back loops (<i>1 stitch decreased; leans left</i>)		2/2 RT: Slip 2 stitches to CN and <i>hold in back</i> . Knit 2 stitches from L needle. Purl 2 stitches from CN
	P2tog: Purl two stitches together (<i>1 stitch decreased</i>)		2/3 LT: Slip 2 stitches to CN and <i>hold in front</i> . Purl 3 stitches from L needle. Knit 2 stitches from CN
	2/1 LT: Slip 2 stitches to CN and <i>hold in front</i> . Purl 1 stitch from L needle. Knit 2 stitches from CN		2/3 RT: Slip 3 stitches to CN and <i>hold in back</i> . Knit 2 stitches from L needle. Purl 3 stitches from CN
	2/1 RT: Slip 1 stitch to CN and <i>hold in back</i> . Knit 2 stitches from L needle. Purl stitch from CN		Scroll Left: Slip 2 stitches to CN and <i>hold in front</i> . Purl 1, then knit 2 from L needle. Knit 2 stitches from CN
			Scroll Right: Slip 3 stitches to CN and <i>hold in back</i> . Knit 2 stitches from L needle. Knit 2, then purl 1 from CN

SCROLLWORK CABLE CHART

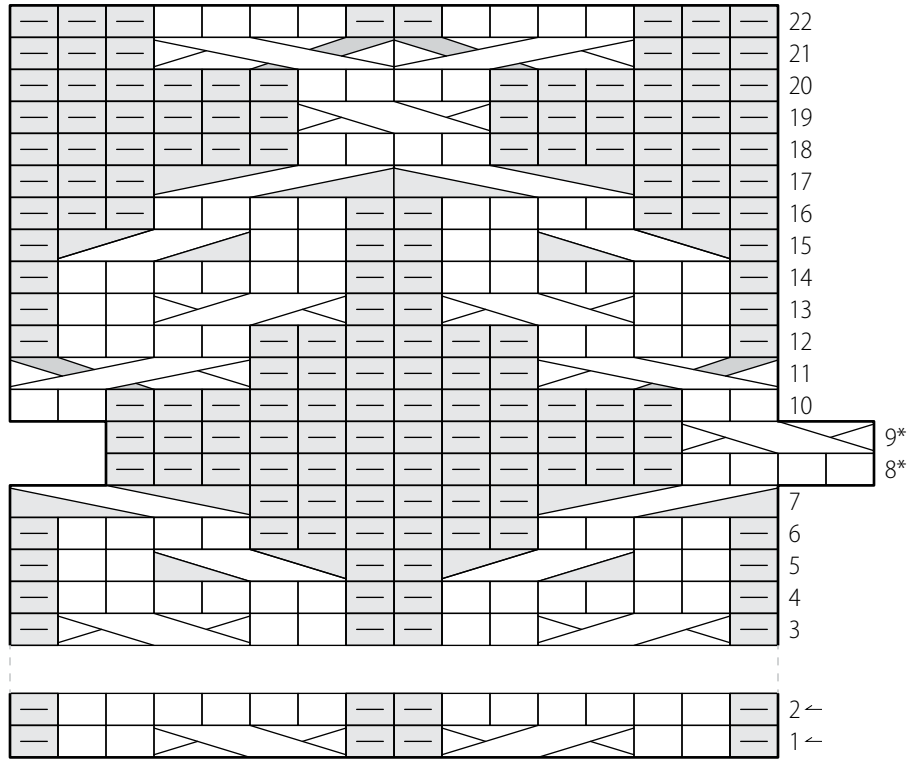

CROWN CHART

