



ROSEBUD

GARTER HAT WITH LARGE CABLED BRAID

by Jared Flood



BLUEPRINT

MATERIALS

Approximately 140 (160) yards of worsted weight wool yarn
1 (2) skeins of Brooklyn Tweed *Shelter* (100% American Targhee-Columbia Wool; 140 yards/50g)
Samples shown in "Fossil" (small) and "Nest" (slouchy)

GAUGE

4½ stitches and 9 rounds (4½ ridges) = 1" in Garter Stitch with Gauge Needle

NEEDLES

Gauge Needle: one 16" circular and one set of DPNs in size needed to obtain gauge as listed above
One 16" circular two sizes smaller than Gauge Needle
Suggested sizes: US 8/5 mm & US 6/4mm

SIZES

Average Adult Small Hat/Tam (Longer Slouchy Hat)
To fit head sizes 20-23¾"

FINISHED DIMENSIONS

18" circumference at brim, 22½" circumference at widest point; blocked and unstretched
7¼ (8¾)" height from base of brim to top-center of crown

TOOLS

Two stitch markers, blunt tapestry needle, cable needle (CN), 9-10" dinner plate for blocking if traditional tam shape is desired (optional)

SKILL LEVEL

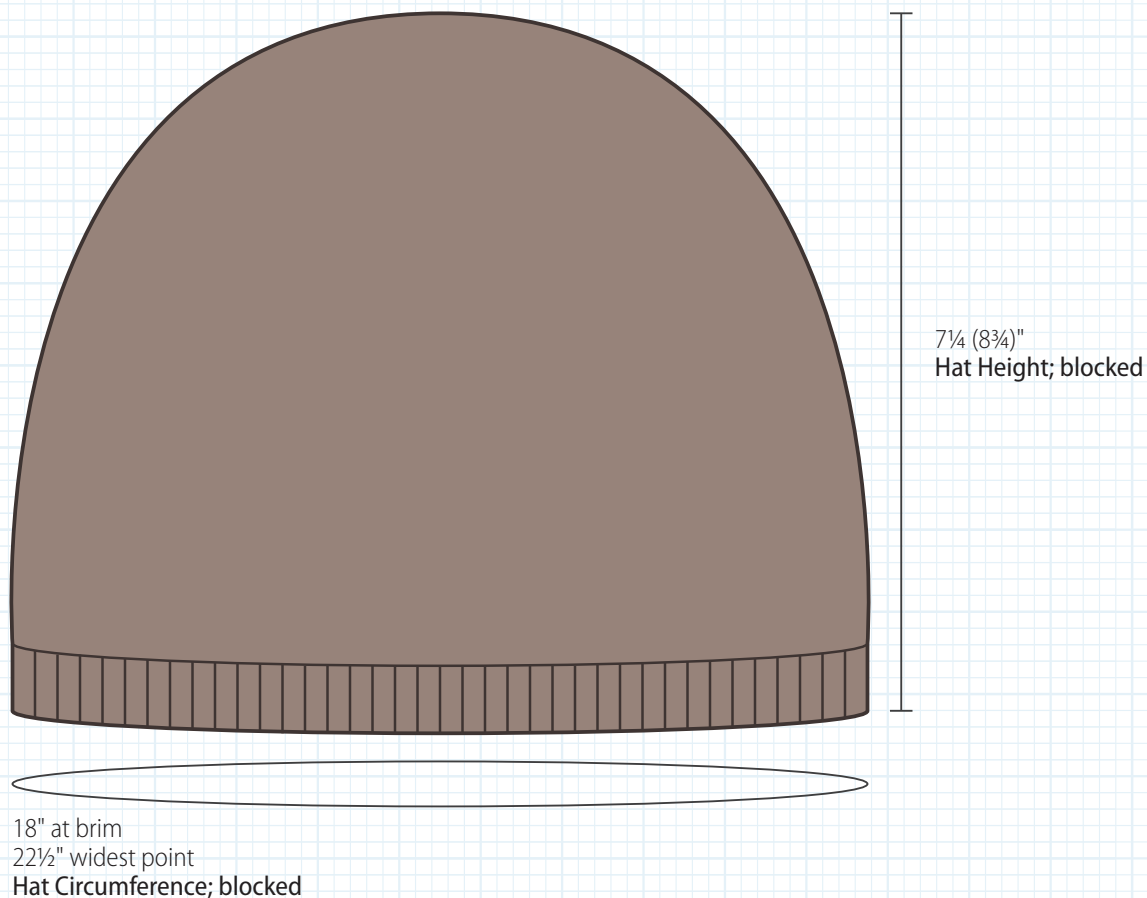
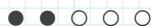

ROSEBUD

This classic hat, which features a large cabled braid over a field of Garter Stitch, comes in two sizes: a smaller version (which can be finished in a traditional Tam shape) or a longer, slouchy version. The 2x2 ribbed brim integrates directly into the plaited braid and the crown shaping occurs in concentric rings (similar to a round-yoked sweater) for a clean finish.

BRIM

With smaller needle cast on 84 stitches. Place a marker and join work into the round, being careful not to twist your ring of stitches.

Setup Round: *Knit 2, purl 2; repeat from * 3 more times, knit 2, place second marker, **purl 2, knit 2; repeat from ** until 2 stitches remain in round, purl 2.

You now have two markers on your needle, with 18 stitches between them. The first marker will always indicate your beginning-of-round.

Next Round: *Knit 2, purl 2; repeat from * to end of round.

Repeat the last round, establishing 2x2 ribbing, six (nine) more times.

You will now begin working the stitches between your markers from the Rosebud Chart. The remaining stitches in your round will be worked in Garter Stitch for the remainder of hat.

Round 1: Work Round 1 of Chart until you reach second marker, *purl 2, knit 2; repeat from * until 2 stitches remain in round, purl 2.

Round 2: Work Round 2 of Chart until you reach second marker, *purl 2, knit 2; repeat from * until 2 stitches remain in round, purl 2.

Round 3: Work Round 3 of Chart until you reach second marker, *knit 6, make 1; repeat from * until 6 stitches remain, knit 6.

Switch to Gauge Needle before working next round.

Round 4: Work Round 4 of Chart until you reach second marker, purl to the end of round.

Round 5: Work Round 5 of Chart until you reach second marker, *knit 7, make 1; repeat from * until 6 stitches remain, knit 6.

Round 6: Work Round 6 of Chart until you reach second marker, purl to the end of round.

Round 7: Work Round 7 of Chart until you reach second marker, knit to the end of round.

You now have a total of 116 stitches on your needle – 30 stitches between your markers, and 86 outside of your markers. You have established the Rosebud Chart between your markers, and Garter Stitch over the remaining stitches.

From this point you will continue working the chart as directed, maintaining Garter Stitch (knitting stitches on odd-numbered rows & purling stitches on even-numbered rows) over remaining stitches throughout remainder of piece.

Over the next 28 (42) rounds, work Rounds 8-21 of Rosebud Chart two (three) times, maintaining Garter Stitch as instructed above.

Upon completion of Round 21 of chart the second (third) time, you will have 116 stitches on your needle.



CROWN SHAPING

You will now begin shaping the crown of your hat. Switch to DPNs when your round becomes too small to continue on circulars.

Round 22: Work Round 22 of Chart until you reach second marker, purl to the end of round.

Round 23 (Decrease): Work Round 23 of Chart until you reach second marker, *knit 3, k2tog; repeat from * until 1 stitch remains in round, knit 1. *97 stitches now in round.*

Rounds 24-26: On each round, work corresponding rounds of Chart until you reach second marker, work stitches after second marker in Garter Stitch to end of round.

Round 27 (Decrease): Work Round 27 of Chart until you reach second marker, *knit 2, k2tog; repeat from * until 1 stitch remains in round, knit 1. *76 stitches now in round.*

Rounds 28-30: Work corresponding rounds of Chart until you reach second marker, work stitches after second marker in Garter Stitch to end of round.

Round 31 (Decrease): Work Round 31 of Chart until you reach second marker, *knit 2, k2tog; repeat from * until you reach the end of round. *60 stitches now in round.*

Rounds 32-34: Work corresponding rounds of Chart until you reach second marker, work stitches after second marker in Garter Stitch to end of round.

Round 35 (Decrease): Work Round 35 of Chart until you reach second marker, *knit 1, k2tog; repeat from * to end of round. *42 stitches now in round.*

Round 36: Work round 36 of Chart until you reach second marker, purl to end of round.

Round 37 (Decrease): Work Round 37 of Chart until you reach second marker, *k2tog; repeat from * to end of round. *24 stitches now on needle.*

Round 38: Work round 38 of Chart until you reach second marker, purl to end of round.

Round 39 (Decrease): Knit 1, purl 1, knit 1, k2tog, purl 1, knit 1, slip marker, *k2tog, knit 1; repeat from * until 1 stitch remains in round, knit 1. (This row is not on Chart)

Crown shaping complete; there are now 15 stitches on your needles.

Break yarn, leaving a 7" tail. With tapestry needle, thread yarn tail through remaining stitches and pull tightly to close top of hat. Weave in yarn tail invisibly on the WS of fabric.



FINISHING

Because of the type of crown decreasing employed on this hat, a full wet-block is highly recommended for best results. Before blocking, the crown fabric may pucker slightly; blocking the hat will make this fabric lay flat and become a cohesive whole.

Wet-block hat as follows: Fill a sink with warm water, adding a small amount of no-rinse wool wash. Submerge finished piece in water, gently squeezing out any air bubbles from fabric. Soak work for 10 to 15 minutes.

Drain sink and squeeze as much water out of your piece as possible, being careful never to wring or twist the fabric.

Now, roll your hat between two clean towels "burrito" style and stomp on the towel roll to remove excess moisture. Remove hat from towels -- it should feel damp but not saturated.

SMALL SIZE

For a more subtle shape (pictured), shape your hat over a soup bowl approximately 7" in diameter, being careful not to stretch the ribbing at base. Flatten and smooth crown before leaving hat to air dry.

For a traditional tam shape, carefully stretch the mid-point of hat around a dinner plate or other circular form approximately 9-10" in diameter, being careful not to stretch ribbing at base. Flatten and smooth crown before leaving hat to air dry.

LARGE SIZE

Lay hat flat on a clean, dry (water-resistant) surface to air dry. For best results, rotate and re-flatten hat every 2 or 3 hours, to keep permanent (until next blocking/washing) creases from forming in your fabric. If hat does dry with creases, these can always be steamed out later.

After hat is completely dry, weave in any remaining ends invisibly on WS of fabric.







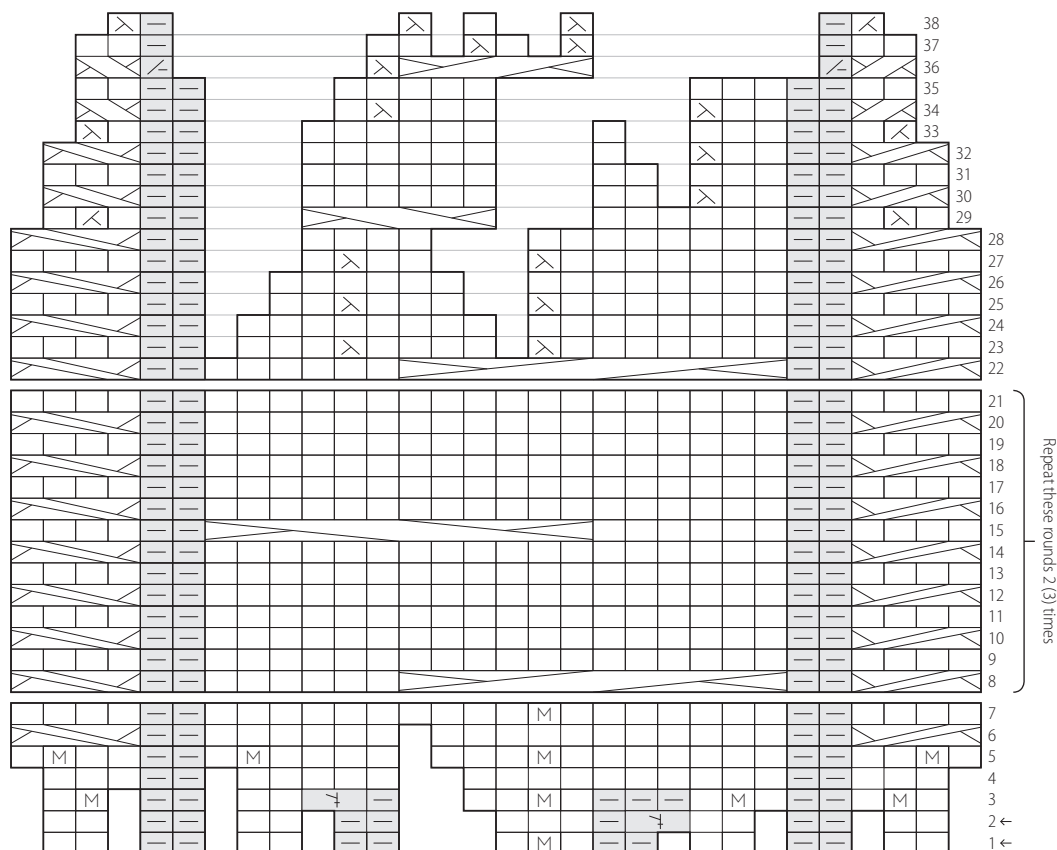













ROSEBUD CHART

Rosebud Chart is worked one time on every round between beginning-of-round marker and second marker. All rounds are read from right to left. Chart begins as an 18-stitch motif before working Round 1 and increases to a 30-stitch motif by Round 8. You will work Rounds 8-21 two (three) times before proceeding to Crown Shaping.



LEGEND

- | | | | |
|---|--|---|---|
|  KNIT | Knit stitch |  1/1 LC | Slip 1 stitch to CN and <i>hold in front</i> . Knit 1 stitch from L needle. Knit stitch from CN |
|  PURL | Purl stitch |  1/1 RC | Slip 1 stitch to CN and <i>hold in back</i> . Knit 1 stitch from L needle. Knit stitch from CN |
|  K2TOG | Knit two stitches together (Right-Leaning Decrease) |  1/2 LC | Slip 1 stitch to CN and <i>hold in front</i> . Knit 2 stitches from L needle. Knit stitch from CN |
|  SSK | Slip 1 stitch from L to R needle as if to knit, replace this stitch on L needle in its new orientation and knit two together through the back loop (Left-Leaning Decrease) |  1/2 RC | Slip 2 stitches to CN and <i>hold in back</i> . Knit 1 stitch from L needle. Knit 2 stitches from CN |
|  P2TOG | Purl two stitches together (1 stitch decreased) |  1/3 LC | Slip 1 stitch to CN and <i>hold in front</i> . Knit 3 stitches from L needle. Knit 1 stitch from CN |
|  M1 | Lift the bar from row below onto L needle tip. Knit this stitch, twisting it to prevent a hole. |  1/3 RC | Slip 3 stitches to CN and <i>hold in back</i> . Knit 1 stitch from L needle. Knit 3 stitches from CN |
|  PFB | Purl into the front and back of same stitch (1 stitch increased) |  3/3 LC | Slip 3 stitches to CN and <i>hold in front</i> . Knit 3 stitches from L needle. Knit 3 stitches from CN |
|  6/6 LC | |  3/3 RC | Slip 3 stitches to CN and <i>hold in back</i> . Knit 3 stitches from L needle. Knit 3 stitches from CN |
|  6/6 RC | |  6/6 LC | Slip 6 stitches to CN and <i>hold in front</i> . Knit 6 stitches from L needle. Knit 6 stitches from CN |
| | |  6/6 RC | Slip 6 stitches to CN and <i>hold in back</i> . Knit 6 stitches from L needle. Knit 6 stitches from CN |