



www.fine-tek.com

Guided Wave Radar Level Transmitter



PRODUCT INTRODUCTION

OPERATING PRINCIPLE

The guided wave radar level transmitter is a solid and liquid level measuring instrument commonly used in the industry. It transmits electromagnetic pulses along with the steel wire cable or tube/rod to propagate at the speed of light; when these encounter the surface of medium to be measured, the pulses will be partly reflected to form an echo wave and returned to the pulse transmission device along the same path, and the height of liquid level can be calculated.

The guided wave radar level transmitter uses advanced echo wave processing technology with a wide range of product applications that is capable of measuring the low dielectric constant of solid buck; and capable of measuring the solid level, liquid level and medium surface. The product models include coaxial, tube/rod, steel wire cable type for the customer's choice, suitable for high temperature and high pressure medium liquid level measurement.

TEST STANDARDS

- High voltage :IEC60947-2
- Insulation resistance :IEC60092-504
- Power supply variation :IEC60092-504
- Power supply failure :IEC60092-504
- Electrical burst testing :IEC61000-4-4
- Voltage DIPS :IEC61000-4-11
- Humidity :IEC60068-2-30
- High/Low temperature test :IEC60068-2-38
- IP protection rating :IEC60529

FEATURES

- Meets the various measurement requirements of different temperature, pressure and medium.
- Contact measuring, capable of overcoming the steam, foam and stirring effects.
- 4~20 mA / 2 lead wires, simple wiring, low power consumption (2.4W max.).
- 128*64 LCM Display, easy on-site adjustment.
- Display distance, level, percentage, current 4~20 mA.
- Unique algorithms and echo wave processing technology can be used under various types of complex work conditions.
- Echo wave graphics display function, to display the signal waveform inside the tank, can be used for background noise processing.
- Operation Interface Language Selection: Traditional Chinese, Simplified Chinese, English. Capable of simulating output current signal of 4mA, 20mA.

APPLICATION AREAS

- Power plant
- Chemical plant
- Cement plant
- Water treatment
- Paper mill plant
- Steel plant
- Refinery plant

SPECIFICATION

<p>Dimensions (Unit: mm)</p>			
<p>Model</p>	<p>JTR301</p>	<p>JTR301</p>	<p>JTR305</p>
<p>Medium of the material</p>	<p>Liquid</p>		<p>Low Dielectric Liquid</p>
<p>Min. Dielectric coefficient (constant)</p>	<p>2.0</p>		<p>1.6</p>
<p>Measuring range</p>	<p>6m</p>	<p>20m</p>	<p>6m</p>
<p>Accuracy</p>	<p>± 5mm</p>		
<p>Repeatability</p>	<p>± 3mm</p>		
<p>Ambient temperature</p>	<p>-40~80°C</p>		
<p>Operating temperature</p>	<p>-40~150°C</p>		
<p>Operating pressure</p>	<p>0~60Bar(25°C)</p>		
<p>Power supply</p>	<p>16~30Vdc Loop Power, 16~30Vdc 4-Wire</p>		
<p>Analog output</p>	<p>4~20mA</p>		
<p>Current distinguishability</p>	<p>1.6uA</p>		
<p>Load impedance</p>	<p>(Vs-16)/0.022 Ohm for 2-Wire, 300 Ohm for 4-Wire>16V</p>		
<p>Digital Communication</p>	<p>HART 7.0 for 2-Wire, Modbus for 4-Wire</p>		
<p>Housing material</p>	<p>Aluminum alloy</p>		
<p>Protection rating</p>	<p>IP67</p>		
<p>Antenna type</p>	<p>Tube/Rod type</p>	<p>Steel wire cable type</p>	<p>Coaxial type</p>
<p>Minimum connection</p>	<p>3/4"PF</p>		

SPECIFICATION

<p>Dimensions (Unit: mm)</p>			
Model	JTR302	JTR302	JTR30A
Medium of the material	Solid		Liquid/Solid
Min. Dielectric coefficient (constant)	2.0		
Measuring range	6m	20m	6m
Accuracy	± 5mm		
Repeatability	± 3mm		
Ambient temperature	-40~80°C		
Operating temperature	-40~150°C		
Operating pressure	0~60Bar(25°C)		
Power supply	16~30Vdc Loop Power, 16~30Vdc 4-Wire		
Analog output	4~20mA		
Current distinguishability	1.6uA		
Load impedance	(Vs-16)/0.022 Ohm for 2-Wire, 300 Ohm for 4-Wire>16V		
Digital Communication	HART 7.0 for 2-Wire, Modbus for 4-Wire		
Housing material	Aluminum alloy		
Protection rating	IP67		
Antenna type	Tube/Rod type	Steel wire cable type	Tube/Rod type
Minimum connection	1"PF		1"(3A)

SPECIFICATION (HIGH TEMPERATURE TYPE)



NEPSI PROOF NO.GYB17.1201X Ex ia IIC T2~T4 Ga

<p>Dimensions (Unit: mm)</p>			
<p>Model</p>	<p>JTR301</p>	<p>JTR302</p>	<p>JTR305</p>
<p>Medium of the material</p>	<p>Liquid</p>	<p>Solid</p>	<p>Low Dielectric Liquid</p>
<p>Min. Dielectric coefficient (constant)</p>	<p>2.0</p>		<p>1.6</p>
<p>Measuring range</p>	<p>6m</p>		
<p>Accuracy</p>	<p>± 5mm</p>		
<p>Repeatability</p>	<p>± 3mm</p>		
<p>Ambient temperature</p>	<p>-40~80°C</p>		
<p>Operating temperature</p>	<p>-40~230°C</p>		
<p>Operating pressure</p>	<p>0~60Bar(25°C)</p>		
<p>Power supply</p>	<p>16~30Vdc Loop Power, 16~30Vdc 4-Wire</p>		
<p>Analog output</p>	<p>4~20mA</p>		
<p>Current distinguishability</p>	<p>1.6uA</p>		
<p>Load impedance</p>	<p>(Vs-16)/0.022 Ohm for 2-Wire, 300 Ohm for 4-Wire>16V</p>		
<p>Digital Communication</p>	<p>HART 7.0 for 2-Wire, Modbus for 4-Wire</p>		
<p>Housing material</p>	<p>Aluminum alloy</p>		
<p>Protection rating</p>	<p>IP67</p>		
<p>Antenna type</p>	<p>Tube/Rod type</p>		<p>Coaxial type</p>
<p>Minimum connection</p>	<p>3/4"PF</p>	<p>1"PF</p>	<p>3/4"PF</p>

FUNCTIONAL PRINCIPLE

LIQUID LEVEL MEASUREMENT

High frequency microwave pulses travel along the steel wire cable or tube/rod. When they reach the medium surface, the microwave pulses are reflected. The pulse operating time is calculated and outputted by the electronic instrument of this meter as the liquid level height.

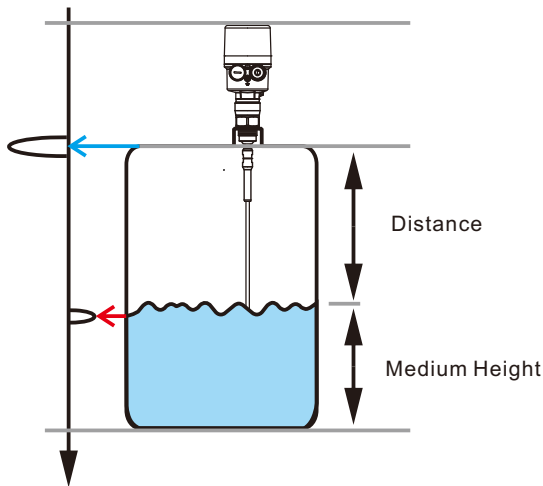

BOTTOM SENSING DETECTION TRACKING TECHNOLOGY

This Meter is equipped with bottom sensing detection tracking mode, when the measured medium has a low dielectric constant, in order to increase the sensitivity. This feature is useful such as in the plastic particles, packing chips or in liquefied containers. When the dielectric constant is between 3 and 10, as long as the echo wave signal cannot be detected, the bottom sensing detection tracking function will be automatically activated.

The calculation of the measured value uses the dielectric constant last recorded; the accuracy of the meter depends on the stability of the dielectric constant.

If the medium's dielectric constant is less than 3, the bottom sensing detection tracking function is automatically activated throughout the process. The medium's dielectric constant must be input as a stable dielectric constant is important in the measurement.

MEASURING RANGE

The bench-mark of the measuring range is the thread or flange contact surface of the sensor. It should be noted that the measuring range is below the reference plane to the bottom of the induction rod and the upper and lower blind areas that cannot be measured. The default value, measuring range of this meter is set up with "water" as the test medium.

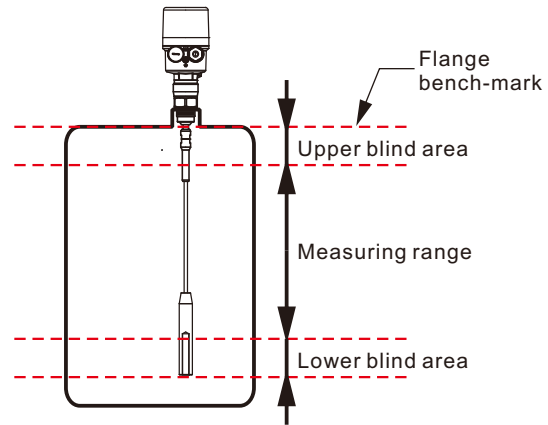

High dielectric constant coefficient (constant) ($\epsilon > 10$):

Upper blind area: <200mm

Lower blind area: <50mm

Low dielectric constant coefficient (constant) ($\epsilon < 10$):

Upper blind area: <500mm

Lower blind area: <100mm

FUNCTIONAL PRINCIPLE

DUAL LIQUID LEVEL INTERFACE MEASUREMENT

High frequency microwave pulses travel along the steel wire cable or tube/rod. When they reach the medium surface, part of the microwave pulses are reflected. The other part penetrates through the upper layer of medium and generates the second reflection at the interface between upper and lower layers of the medium. Two pulse operating time periods are calculated and outputted by the electronic instrument of this meter as the dual liquid level heights.

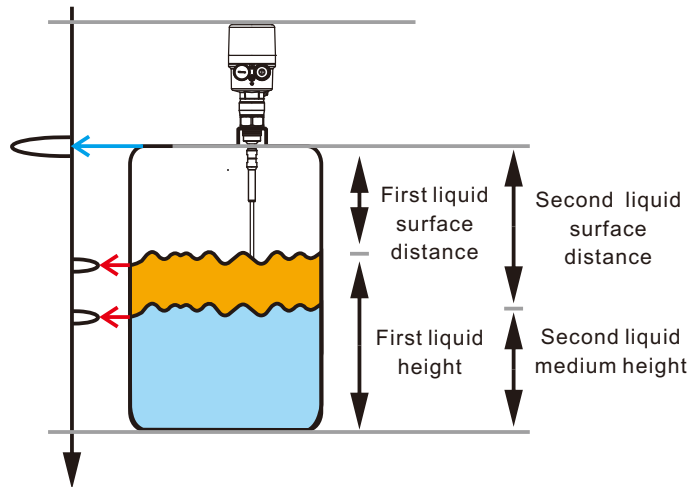

Dual Liquid Level Interface Measuring Condition:

Upper layer medium (L2):

The upper layer medium must be nonconductive dielectric; the dielectric constant of upper layer medium or the actual distance to interface must be known; the dielectric constant of the upper layer medium needs to be greater than 1.6.

The upper layer medium must be stable and the medium cannot be changed or mixed; the upper layer medium must be uniform, and the minimum thickness of the upper layer medium without layering shall be greater than 50 mm (1.97 inches) and clearly separated between the upper layer and lower layer mediums. If there is emulsion phase or debris layer, the maximum thickness shall not be greater than 50 mm (1.97 inches), better measuring results can be achieved without foam on the surface if possible.

Lower layer medium (L1):

The dielectric constant of lower layer must be 10 greater than the dielectric constant of lower layer, preferably conductive medium.

For example, if the dielectric constant of upper layer is 2, the dielectric constant of lower layer shall be at least 12.

Gas layer (L3):

This layer is the mixture of air or gas

Dual Liquid Level Interface Measurement output signal setting:

The meter shall be set up for using in "Separate layers interface measurement", used in interface measurement of two types of liquid, dual analog output version can be selected and adjusted in the setting menu.

INSTALLATION INFORMATION

Please note that when installing the JTR3 series product in a metal container, the spacing from the other devices in the container shall be at least 300 mm (12 in).

When installing in a non-metal container, the spacing from the container wall shall be at least 500 mm (19.7 in). It is necessary to ensure the induction rod must not touch any device or tank wall during operation.

It is recommended to fix the bottom of the rod in the tank to reduce the induction rod shaking when using steel wire cable type induction rod.

Please note that this meter has upper and lower blind areas that it is impossible to measure the bottom end of the induction rod.

When the welding operation is required during the installation process, please remove the electronic module of the sensor from the terminal box before starting the welding work to avoid damage to the electronic equipment due to induction coupling or other failures.

When used in plastic/glass containers, it is necessary to use the meter type with flange or place a piece of metal plate ($\phi > 200\text{mm} / 8\text{in}$) under the processing connection when locked. The metal plate shall be directly contacted with the processing connection.

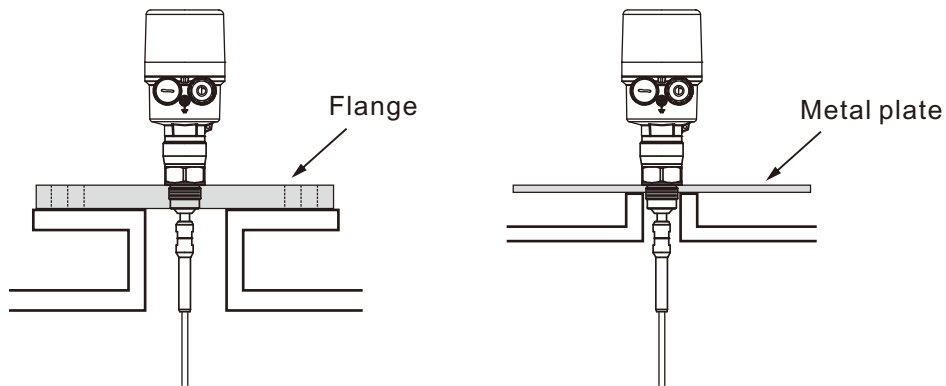

During installation, please avoid using the extension tube on the container. Please install the sensor leveled with the top cover of the container as possible. If this cannot be done, please use a shorter extension tube. Please do not install this instrument at the inlet to ensure that the meter is in a stable position in the medium and not in the inflow position of the liquid to avoid false measurements when the liquid flows in.

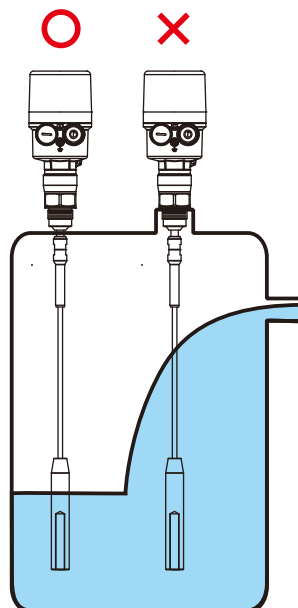

MODEL NUMBER / ORDER CODE COMPARISON TABLE

Model Number	Order Code
JTR301	JTR1□□□□-A1 JTR1□□□□-A2
JTR302	JTR1□□□□-B1 JTR1□□□□-B2
JTR305	JTR1□□□□-A3
JTR30A	JTR103□□-E1

ORDERING INFORMATION

JTR1 ⁰⁵ ⁰⁶ ⁰⁷ ⁰⁸ - ⁰⁹ ¹⁰ ¹¹ ¹² ¹³ ¹⁴ ¹⁵ ¹⁶ ¹⁷ ¹⁸ ¹⁹ ²⁰ ²¹ ²² ²³

05 06 Model
 00: Standard
 02: Hi-temperation
 03: Sanitary

07 08 Certification
 00: None
 7B: NEPSI-Exia

09 10 Probe Type
 A1: Rod type for liquid 6mm
 A2: Steel wire cable type for liquid 4mm
 A3: Coaxial type 21.7mm
 B1: rod type for solid
 B2: cable type for solid
 E1: Sanitary rod

11 12 Probe material
 MA: SUS 304
 MB: SUS 316
 MC: SUS 316L

Connection

13 14
 Flange
 AJ: JIS-RF
 AN: ANSI-RF
 AR: DIN-RF
 AI : 3A

 Thread
 AA: JIS
 AC: ANSI

15 16
 A7: 3/4"
 A8: 1"
 B1: 1-1/2"
 B2: 2"
 B5: 3"
 B7: 4"
 E1: DN40

17 18
 00: None
 01: PT male
 03: PF male
 07: NPT male
 13: GAS male
 40: 5 kg/cm²
 48: 150 Lbs
 56: PN 6
 57: PN10
 59: PN25

(Next page)



⑤⑥⑦⑧⑨⑩⑪⑫⑬⑭⑮⑯⑰⑱⑲⑳㉑㉒㉓
JTR1 -

⑲ **Output/input**

- B: Loop Power 16 ~ 30 Vdc with HART
- D: Loop Power 16 ~ 30 Vdc X 2 with HART
- E: 4-Wire 16 ~ 30Vdc 4~20mA with RS485
- H: 4-Wire 16 ~ 30Vdc, 4~20mA X2 with RS485

⑳ ㉑ ㉒ ㉓ **Length**

Code	Probe Length
0500~6000	500~6000mm
0500~A200	500~20000mm

SUCCESS STORY



Water purification barrel



Copper sulfate storage tank



High temperature boiler



Food factory - bean dregs storage barrel

Global Network

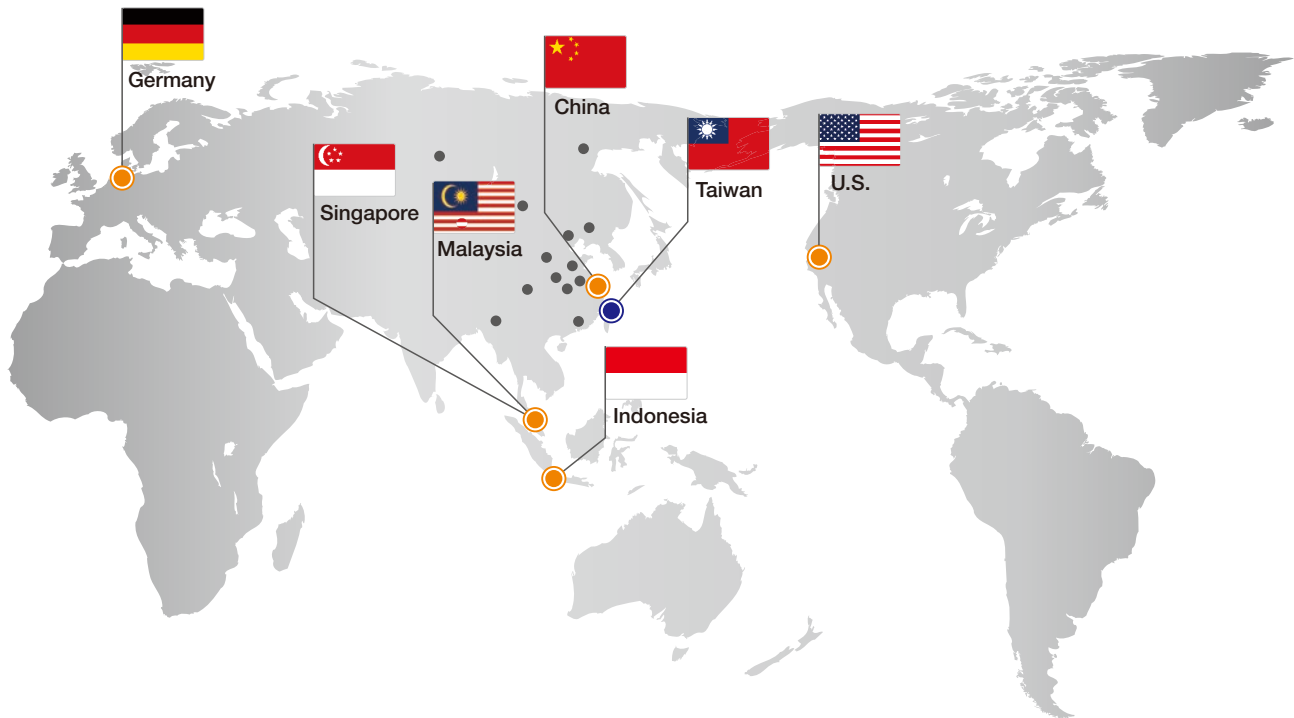

■ Asia

● Taiwan

FineTek Co., Ltd. - Taipei Head Quarter

No.16, Tzuchiang St., Tucheng Industrial Park
New Taipei City 236, Taiwan
TEL: 886-2-2269-6789
FAX: 886-2-2268-6682
EMAIL: info@fine-tek.com

● China

Fine automation Co., Ltd. - Shanghai Factory

No.451 DuHui Rd, MinHang District, Shanghai,
China 201109
TEL: 86-21-6490-7260
EMAIL: info.sh@fine-tek.com

● Singapore

FineTek Pte Ltd. - Singapore Office

No. 60 Kaki Bukit Place, #07-06 Eunos
Techpark 2 Lobby B, Singapore 415979
TEL: 65-6452-6340
EMAIL: info.sg@fine-tek.com

● Indonesia

FineTek Co., Ltd. - Indonesia Office

Ruko Golden 8 Blok H No.38
Gading Serpong, Tangerang, Indonesia
TEL: 62 (021)-2923-1688
EMAIL: info.id@fine-tek.com

● Malaysia

FineTek Co., Ltd. - Malaysia Office

8-05, Plaza Azalea, Persiaran Bandaraya,
Seksyen 14, 40000 Shah Alam, Selangor, Malaysia
TEL: 603-5524-7168
EMAIL: info.my@fine-tek.com

■ North America

● California, U.S.

Aplus Finetek Sensor Inc. - US Office

355 S. Lemon Ave, Suite D, Walnut,
CA 91789
TEL: 1 909 598 2488
FAX: 1 909 598 3188
EMAIL: info@aplusfine.com

■ Europe

● Germany

FineTek GmbH - Germany Office

Bei den Kämpen 26
21220 Seevetal-Ramelsloh, Germany
TEL: +49-(0)4185-8083-12
FAX: +49-(0)4185-8083-80
EMAIL: info@fine-tek.de

● Mütec Instruments GmbH - Germany Office

Bei den Kämpen 26
21220 Seevetal-Ramelsloh, Germany
TEL: +49-(0)4185-8083-0
FAX: +49-(0)4185-8083-80
EMAIL: muetec@muetec.de



Distributor: