

2-way Control Valve type L2F

Gun metal, PN 10, DN 65 – 150 mm

0-2.2.05.01-A

Page 1 of 2



APPLICATIONS

Control valves type L2F are designed for regulating hot water - and cold and hot sea water. The valves are used in connection with one of our temperature regulators in control systems for industrial processes or marine installations.

DESIGN

The valve components - valve body, seats, cone and spindle - are made of sea water resistant materials with connection flanges drilled according to DIN 86021. The connection thread for the actuator is G1B.

FUNCTION

Without the actuator being connected, the valve is held in open position by means of a spring. With pressure on the spindle the valve will close. In connection with our thermostats or electronic actuators, the valves will close at rising temperatures. The linear characteristic will not cease, until the flow has dropped below 4% of the full flow.

TECHNICAL DATA

Materials:

- Valve body, seats and cone	CuSn5Zn5Pb5-CRG
- Spindle	W.no. 1.4436
- O-ring	90 NBR
- Gasket	Reinz-AFM34
Nominal pressure	PN 10
Seating	2 balanced seats
Flow characteristic	Almost linear
Leakage rate	≤ 0.5% of Kvs
Regulating capability	Kvs/Kvr > 25
Flanges drilled according to	DIN 86021 or ANSI Class 150

FEATURES

- Sea water resistant
- Simple design secures reliable controls and reduces costly downtime.
- Location of the pack box in the actuator makes the valve service friendly.
- Reliable and secure due to internal parts of stainless steel.

PRESSURE/TEMPERATURE DIAGRAM

According to DIN 2401

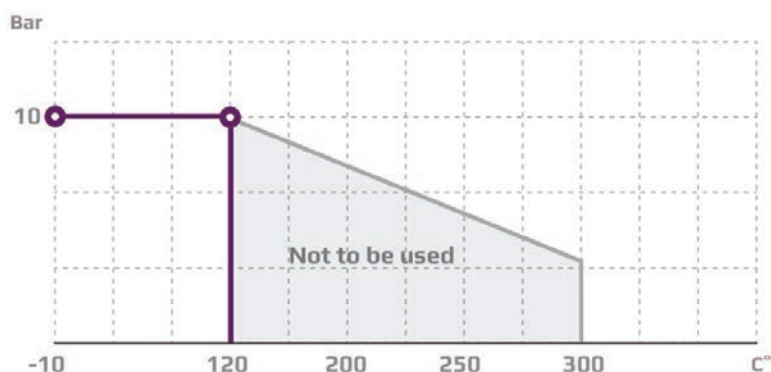

Subject to change without notice.

PORT NUMBERING

The ports of valves type L2F are marked with the figures 1 and 2. The letters in parentheses refer to the corresponding internationally adapted designations.



MOUNTING

The valves can be installed with vertical as well as horizontal spindles. The valves must be mounted in a way that the valve actuator will be exposed to a minimum of moisture and unnecessary vibrations.

DIMENSION SKETCH

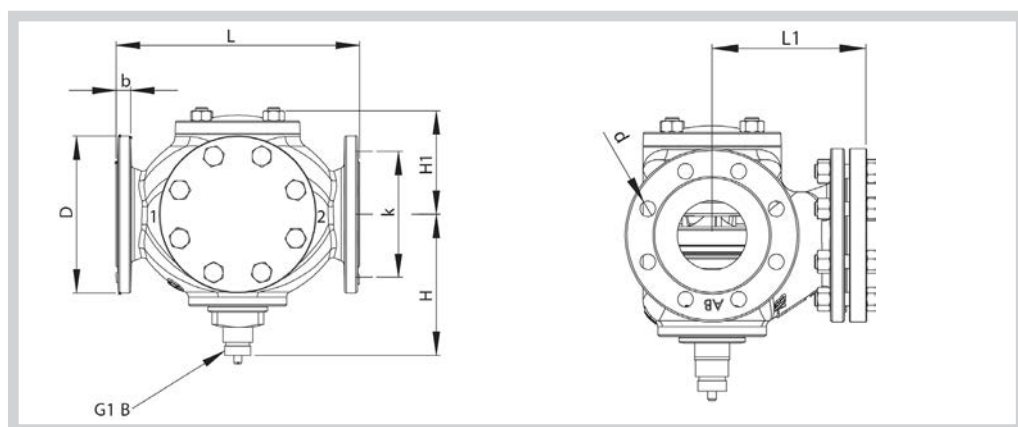

Type	L (mm)	L1 (mm)	H (mm)	H1 (mm)	D (dia.) (mm)	b (mm)	k (dia.) (mm)	d mm dia. (number)
65 L2F	240	150	175	120	185	20	145	18x(4)
80 L2F	260	160	185	125	200	22	160	18x(8)
100 L2F	350	205	195	145	220	22	180	18x(8)
125 L2F	400	275	245	180	250	24	210	18x(8)
150 L2F	480	305	280	189	285	24	240	22x(8)

SPECIFICATIONS

Type	Flange connection DN in mm	Opening (mm)	k_{vs} -value m^3/h	Lifting height (mm)	Weight (kg)
65 L2F	65	65	50	10.50	27
80 L2F	80	80	80	11	36
100 L2F	100	100	125	13	62
125 L2F	125	125	215	18	102
150 L2F	150	150	310	21	145